

# DIAMOND PIER® DP-100E

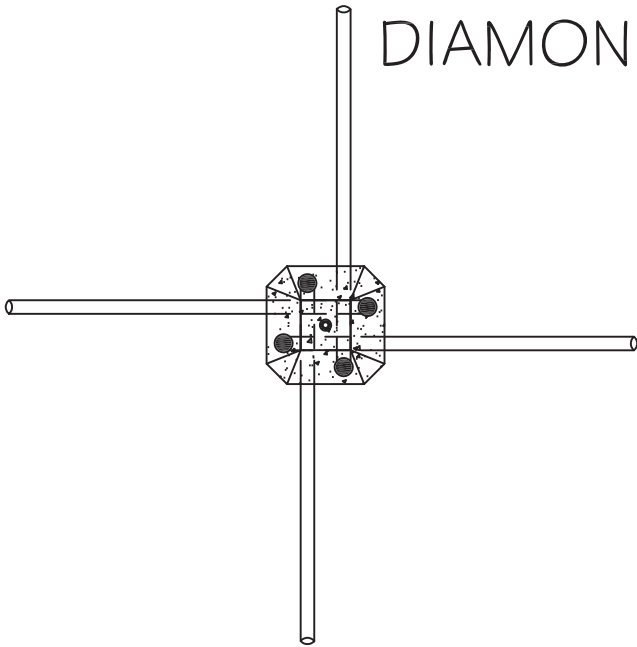

PLAN VIEW W/ PINS

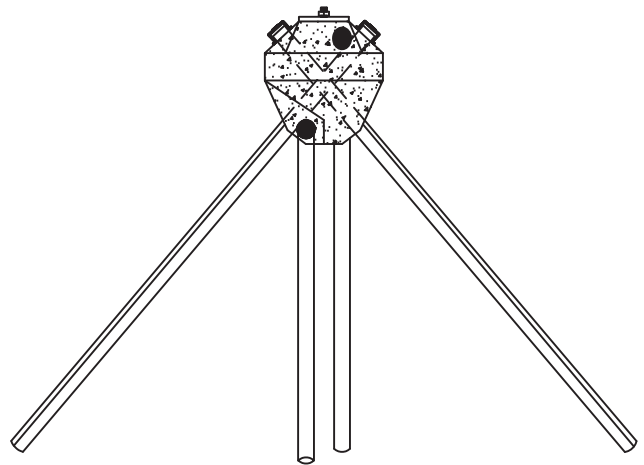

ELEVATION W/ PINS

WEIGHT 96 LBS. (CONCRETE ALONE)  
 1.3 INCHES SQUARE AT MIDPOINT  
 1.4 INCHES HIGH  
 BRACKET SEAT - 5.5" SQUARE

1.5" NOM. DIAMETER GALVANIZED PIPE  
 NOTE: LENGTH VARIES WITH SOIL CONDITIONS  
 SEE MANUFACTURER'S CAPACITY GUIDELINES

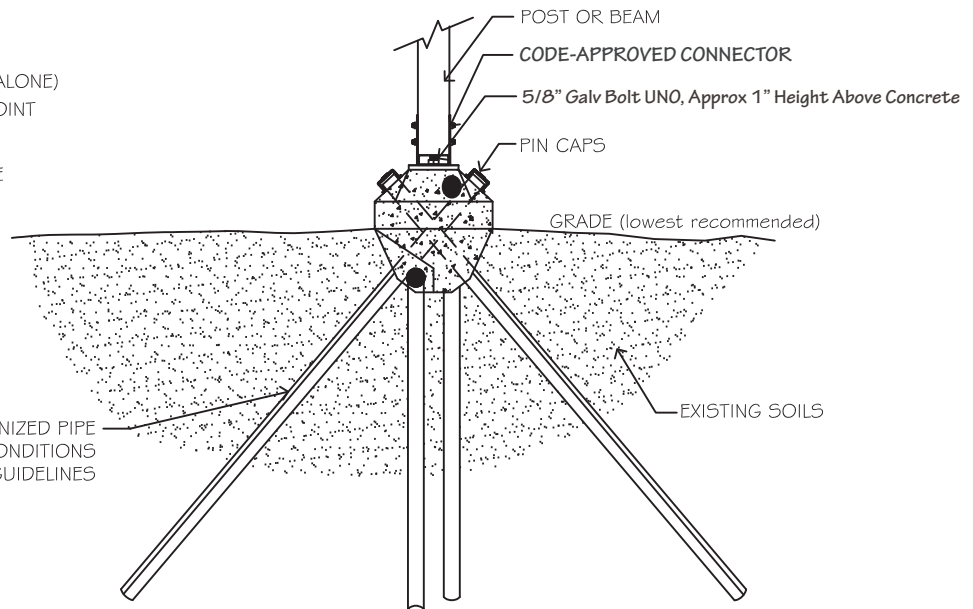

# DIAMOND PIER® DP-100E

US PAT. #5039256, #6910832, & #7326003

ALL DETAILS IN WHOLE OR IN PART, OR ANY PORTION THEREOF, ARE COPYRIGHTED BY PIN FOUNDATIONS, INC., AND MAY BE USED BY THE RECIPIENT OR THEIR ASSIGNS FOR PROJECT APPLICATIONS ONLY.

©2018 PIN FOUNDATIONS, INC. ALL RIGHTS RESERVED. DOC0025/01.2018

PIN FOUNDATIONS, INC.

GIG HARBOR, WASHINGTON  
 (253) 858-8809