

DIAMOND PIER® DP-50

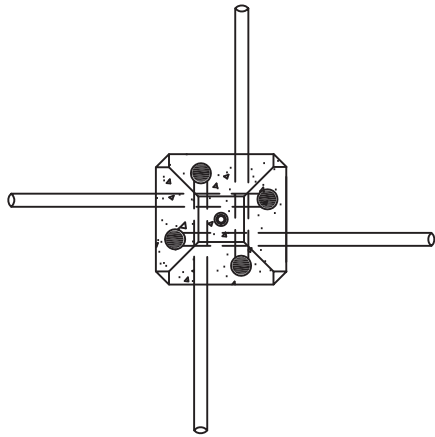

PLAN VIEW W/ PINS

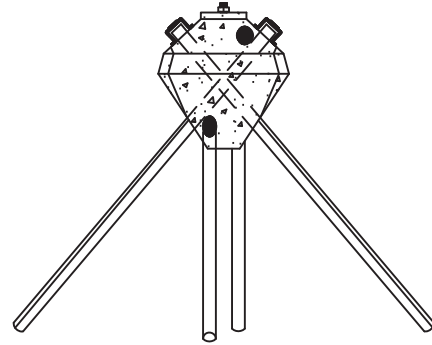

ELEVATION W/ PINS

WEIGHT 54 LBS. (CONCRETE ALONE)
10.5 INCHES SQUARE AT MIDPOINT

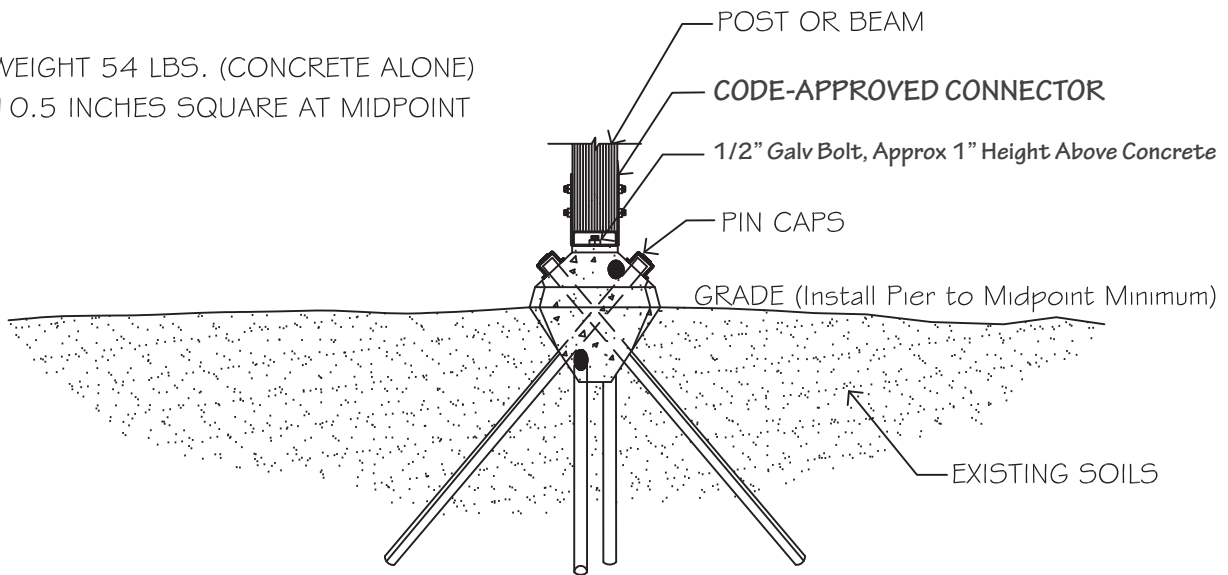

1" NOM. DIAMETER GALVANIZED PINS

SEE MANUFACTURER'S INSTALLATION INSTRUCTIONS

DIAMOND PIER® DP-50

US PAT. #5039256, #6910832, & #7326003

ALL DETAILS IN WHOLE OR IN PART, OR ANY PORTION THEREOF, ARE COPYRIGHTED BY PIN FOUNDATIONS, INC., AND MAY BE USED BY THE RECIPIENT OR THEIR ASSIGNS FOR PROJECT APPLICATIONS ONLY.

©2018 PIN FOUNDATIONS, INC. ALL RIGHTS RESERVED. DOC0023/01.2018

PIN FOUNDATIONS, INC.

GIG HARBOR, WASHINGTON
(253) 858-8809